

# New Scale Technologies

## M3-FS and M3-F Focus Modules

Tiny, all-in-one smart motion modules for positioning optics in OEM cameras

SMALL, PRECISE, SMART ... IN MOTION

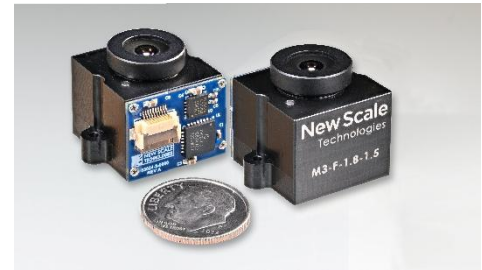

### FEATURES

- **Tiny "all-in-one" solution:** no external control board needed
- **Superior image quality:** sub-micron lens movement with very low tilt. *Now with higher dynamic stability*
- **Low voltage & power:** 3.3 VDC input, zero power position hold
- **Simple system integration:** accepts high-level motion commands over standard serial interface (I2C or SPI)
- **Flexible, production-ready system:** compatible with M8 to M16 lenses and with typical image formats from 1/3" to 1/1.8"
- **Lowest cost, fastest time to market:** Fully-engineered "plug and play" solution

### APPLICATIONS

*High-resolution cameras for miniaturized systems and handheld, portable or mobile instruments*

- In-vitro diagnostics (IVD)
- Robotic inspection
- Miniature microscopes
- Surveillance & remote sensing
- Biometric identification
- Imaging arrays
- Process control & machine vision
- Guidance, targeting & UAVs

### Precision lens control for highest image quality

M3-F and M3-FS focus modules add high-resolution lens motion, with excellent dynamic stability, to the smallest OEM vision systems. Each module is a complete closed-loop motion solution and requires no more space than a typical fixed lens mount. Very low power is needed to move the lens and zero power is needed to hold the lens in any position, making the M3 Focus Module ideal for battery-powered devices.

All M3 smart modules have embedded closed-loop control. They need only simple high-level motion commands from the camera processor, making system integration fast, simple and cost-effective.

Precise lens position control (0.5  $\mu\text{m}$  resolution) and best-in-class bi-directional repeatability enable you to capture the sharpest images in the shortest time. Designed for long life with high performance, M3 modules are not susceptible to temperature or power variations.

### Improved dynamic stability and precision

**The new M3-FS** focus module is a drop-in replacement for the original M3-F focus module. The aluminum structure and innovative ball bearing guide mechanism deliver a 3x improvement in tilt and accuracy. The new M3-FS features superior dynamic stability, minimizing pixel shift with changing camera orientation. This makes it ideal for miniature handheld, portable and mobile systems. Maximum lens diameter is M16.

**The original M3-F** focus module, with molded plastic housing and a pin-bushing guide, remains an economical choice for lower-precision requirements or fixed camera positions. Maximum lens diameter is M12.

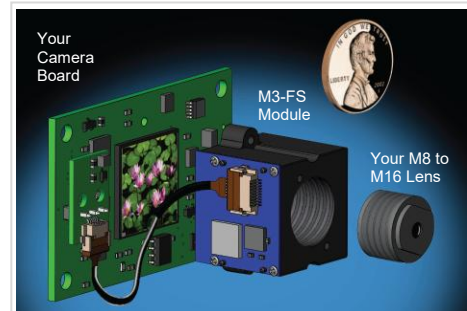

**Small, precise and smart:** M3-FS and M3-F focus modules are easily integrated with your image sensor board and lens. The complete, drop-in focus solution requires no more space than a fixed lens holder.



**All-in-one motion modules** run on 3.3 VDC and can be evaluated using a PC with USB adapter and New Scale Pathway™ software, included in the Developer's Kits.

## Simple integration

### Integration with camera processor

Both the M3-FS and M3-F smart focus modules feature embedded closed-loop control. You provide simple, high-level motion commands from the camera processor over a standard I2C or SPI interface.

### Lens installation and alignment

Install your lens using the threaded inside diameter of the M3 module. The M3-FS accepts a maximum M16 diameter lens, or an M12 lenses with a standard adapter. Smaller lenses may be feasible depending on the optical design. The M3-F accepts a maximum M12 lens directly.

For typical camera integration, “active alignment” is required to align the optical centerline of the lens orthogonal to the image sensor by moving the M3 module and lens as a single assembly.

After alignment, the base of the module is typically secured to the image sensor board using shims, adhesive and screws. The lens back focal distance is then set by rotating the lens in the threads and securing it with a small amount of adhesive in the threads.

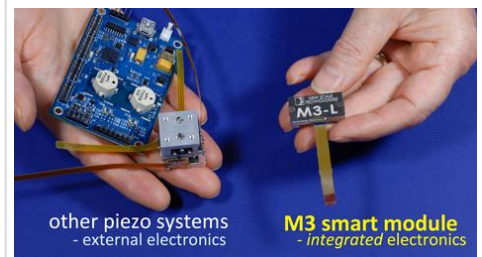

**The M3 Advantage:** New Scale’s M3 micro-mechatronic module platforms provide the smallest, highest resolution, and most repeatable closed-loop positioning solutions available. These “all in-one” smart modules require no separate electronics and are ready to plug-and-play directly with your system processor and power supply. You achieve the fastest time to market with the lowest total cost.

Each M3 smart module is a fully engineered solution that integrates our patented and proprietary motor, drive, sensing, guide and control technologies. These unique components combine to create the world’s smallest closed-loop motion solutions.

## Specifications

Model	M3-F	M3-FS
<b>Lens Type</b> (Lens not included)	Accepts M12x0.5 mm lens. Accepts smaller lenses to M8x0.35 with adapter by special order	Accepts M16x1 mm Accepts M12x0.5 mm with standard adapter. Other sizes by special order.
<b>Lens Weight</b> (note 1)	< 5 grams	< 5 grams (all orientations)
<b>Travel Range</b>	Up to 1.5 mm	Up to 1.5 mm
<b>Housing Dimension</b>	20 x 22 x 16 mm	20 x 23 x 16 mm
<b>Image Sensor Area</b> (image sensor not included)	17 x 17 (see drawing)	17 x 17 (See drawing)
<b>Maximum Speed</b>	5 mm/s	5 mm/s
<b>Resolution</b>	0.5 $\mu$ m	0.5 $\mu$ m
<b>Repeatability</b>	Uni-directional: +/- 8 $\mu$ m Bi-directional: +/- 20 $\mu$ m	Uni-directional: +/- 2.5 $\mu$ m Bi-directional: +/- 5 $\mu$ m
<b>Linear Accuracy</b>	$\pm$ 30 $\mu$ m	$\pm$ 12 $\mu$ m
<b>Static Tilt</b>	<math>\pm 1 degree	<math>\pm 0.7 degree
<b>Dynamic Tilt</b>	<math>\pm 0.15 degrees	<math>\pm 0.05 degrees
<b>Static Concentricity</b>	<math>\pm 0.25 mm	<math>\pm 0.25 mm
<b>Dynamic Concentricity</b>	<math>\pm 0.02 mm	<math>\pm 0.002 mm (Typical)
<b>Input Voltage</b>	3.1 to 3.6 V DC	3.1 to 3.6 V DC
<b>Input Power</b> (note 2)	< 1 W (5mm/s with 5g mass) < 0.13 W quiescent	< 1 W (5mm/s with 5g mass) < 0.13 W quiescent
<b>Temperature /RH</b> (note 3)	5° to 70°C (lower possible) <70% RH non-condensing	5° to 70°C (lower possible) <70% RH non-condensing
<b>Lifetime</b> (note 4)	>2 million cycles (fixed orientation) 500K cycles (any orientation)	>10 million random moves while not exceeding 1.2 km total travel. See note 4
<b>Digital Interface</b>	I <sup>2</sup> C or SPI	I <sup>2</sup> C or SPI
<b>Weight of module</b> (without lens)	5.8 grams	8 grams
<b>Compliance</b>	CE / RoHS	CE / RoHS

Note 1: Fixed orientation may allow for heavier lens operation. Please consult the factory.

Note 2: Power depends on input voltage, speed & load.

Note 3: Consult the factory for lower temperature requirements.

Note 4: M3-FS specification corresponds to 10 million moves with average random move of 120  $\mu$ m. Lifetime depends on application and use case. Please consult factory to discuss your specific system design.

### M3-FS focus module

The M3-FS focus module is a drop-in replacement for the M3-F module. It has the same electrical connections, the same software commands, and nearly identical size. It has a new anodized aluminum housing with preloaded zero clearance ball-bearings for precision motion.

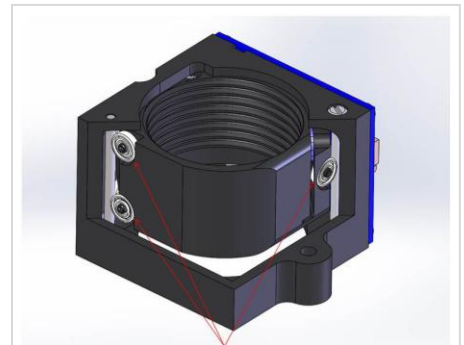

**M3-FS lens motion** guides are preloaded ball bearings with very low friction and zero internal clearance. This precision guide produces excellent lateral stability and minimum pixel shift when the camera is moving and changing orientation.

#### M3-FS-1.8-1.5-M16 focus module – accepts M16x1 threaded lens

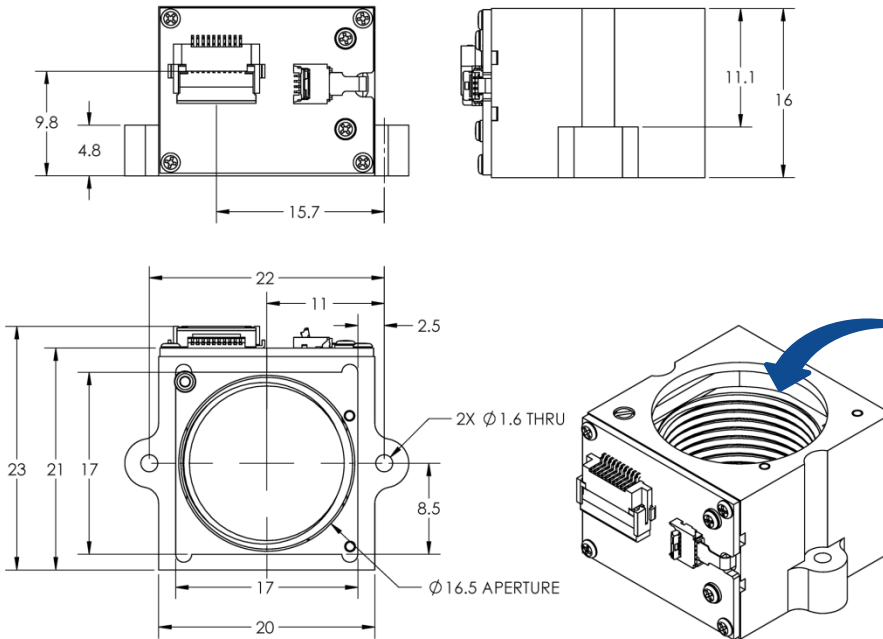

**Kit, M3-FS-M16 to M12 Adapter**  
Threads into M3-FS module to accept M12x0.5 lens

All dimensions in mm

### M3-F focus module

The M3-F focus module has a molded plastic housing with pin-bushing guides for lens motion.

#### M3-F-1.8 focus module - accepts M12x0.5 threaded lens

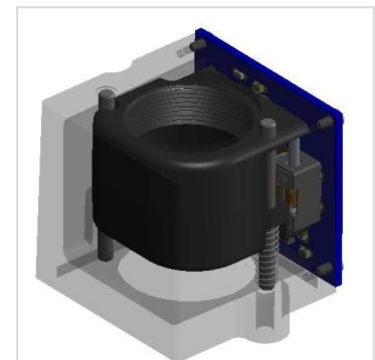
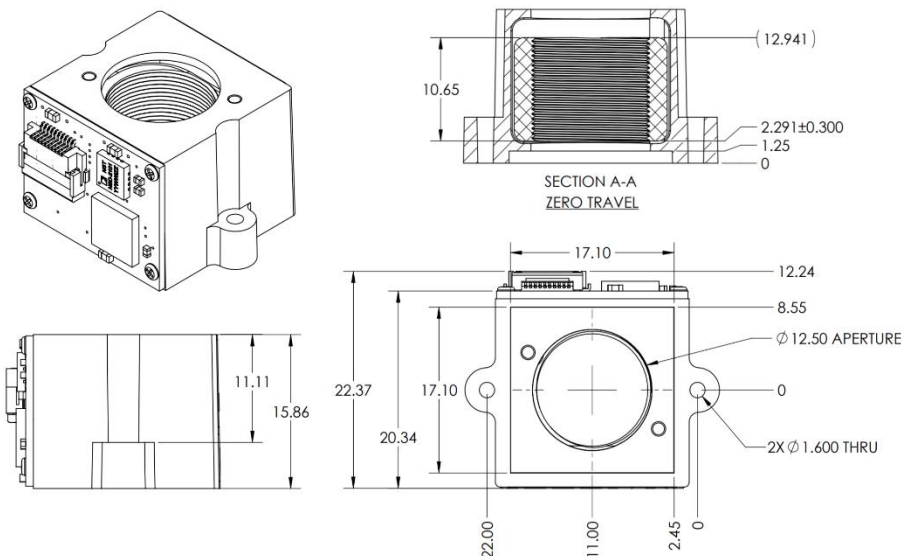

**M3-F has pin-bushing** guides for lens motion.

## Developer's Kits

M3-F and M3-FS Developer's Kits provide convenient engineering evaluation and demonstration of focus in your camera in just a few minutes. New Scale Pathway™ software allows you to perform manual focus operations immediately from your PC.

Developer's Kits are available from select distributors and regional representatives. For links and contact information see <https://www.newscaletech.com/micro-motion-modules/m3-fs-m3-f-focus-modules/>.

## Ordering information

### M3-FS high-performance focus module

NEW M3-FS	Description
<b>DK-M3-FS-1.8--1.5-M12/16</b>	<b>M3-FS Developer's Kit</b> including M3-FS-1.8-1.5-M16 focus module with ball bearing guide. USB adapter, M16 to M12 lens adapter, cables, instructions and New Scale Pathway™ software.
M3-FS-1.8-1.5-M16	M3-FS Smart Focus Module with ball bearing guide For M16x1 threaded lens (lens not included)
M3-FS-1.8-1.5-M12	M3-FS Smart Focus Module with ball bearing guide With adapter for M12x0.5 threaded lens (lens not included)
Kit, M3-FS-M16 to M12 Adapter	Converts M16x1 threaded bore to M12x0.5

### Original M3-F focus module

M3-F	Description
<b>DK-M3-F-1.8-TRK-1.5-S</b>	<b>M3-F Developer's Kit</b> including M3-F module with pin-bushing guide. USB adapter (SPI), cables, instructions and New Scale Pathway™ software.
M3-F	M3-F Smart Focus Module with pin-bushing guide For M12x0.5 threaded lens (lens not included)

## Application-Specific Solutions

We can quickly create customized focus modules to meet your exact OEM specifications including longer travel, custom lens interface, mounting requirements and unique environmental considerations. Contact us to discuss your requirements.

## Learn More

Visit [www.newscaletech.com](http://www.newscaletech.com) for application notes, CAD files, STEP file models and programming guides.

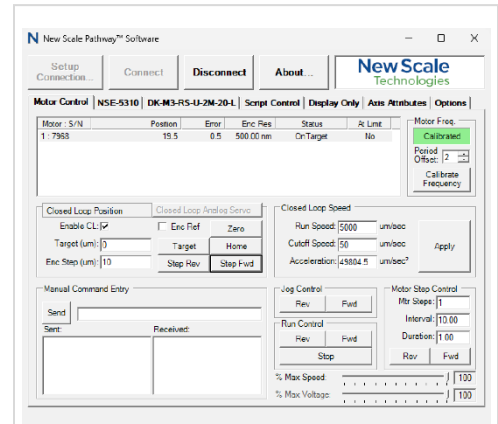

**Developer's Kits** include a focus module, USB adapter, cables and New Scale Pathway™ development software. M3-FS kits include an adapter for M12 lenses. (Lenses not included.)